

Reliability.

It's the defining trait of our company and our forklifts.



UniCarriers' roots extend back over 100 years, and over that time, strong, reliable performance has always been the hallmark of our organization, our people and our equipment.

Today, our unrivaled reliability continues to provide UniCarriers' customers with a competitive edge. And together, we move the merchandise that moves world commerce with greater efficiency, economy and reliability.

When it comes to providing forklifts that make a difference for our customers and theirs...

We Never Quit.



UNICARRIERS
FORKLIFT
UniCarriersAmericas.com

SB-SCX 07-2015 Printed in U.S.A.

UniCarriers® is a registered trademark of UniCarriers Corporation. UniCarriers Americas Corporation reserves the right to make product changes relating to colors, equipment, specifications or available options without notice. For more information, contact your UniCarriers representative.



UNICARRIERS
FORKLIFT



Standup Counterbalanced Forklifts

36 Volt AC-Powered
3,000 / 3,500 / 4,000 lbs. Capacities | Cushion Tire



SCX Series

SCX Series Applications

The SCX Series has zero emissions, so it's good for the environment...while it excels in any environment — from freezers, coolers to loading docks in:

- Food Products Companies
- Warehousing Operations
- Light Manufacturing
- Trucking Operations



Look for these symbols for features available only on UniCarriers forklifts or that provide a proven performance advantage as compared to competitive trucks.



NEVER QUIT.

It defines our forklifts and the company that builds them.

Over the course of a century, the company known as UniCarriers took shape. As we grew and evolved into a US manufacturer with a global reach in nearly 100 countries worldwide, much has changed, but one thing hasn't: our mission. UniCarriers is committed to providing you with the ultimate in reliability, performance, and value.

And that commitment can be seen in the SCX Series, a workhorse that combines extraordinary maneuverability with exceptional performance in a truck that's both powerful and reliable. Specifically designed for applications that require operators to frequently get on and off of the truck, the SCX is loaded with ergonomic features like the lowest entry step in the industry and an inclined floorboard to reduce operator fatigue and maximize productivity. Plus, it's backed by the best standard, limited warranty in the business. All of which makes SCX the preferred choice of operators and the best choice for your bottom line.



Up Your UpTime

Discover reliability features that cut downtime and keep your business up and running



Comfort Zone

Your drivers and your entire operation will benefit from our comfort & productivity features



Power & Performance

100% AC motors and controllers are only the beginning of our performance advantages



Sweet Savings

The SCX is designed to deliver you a low cost of ownership year after year after year



Play It Safe

Safety is everybody's business, and the SCX is all business when it comes to safety



Control Freak

With the SCX, you're in complete control when it comes to managing costs and productivity



Make It Yours

Already well appointed, the SCX can be customized to meet your specific needs



To learn more, and a find a dealer near you, visit UniCarriersAmericas.com

Up Your UpTime

SCX Series stand-up trucks have been specifically designed to use fewer parts, require less scheduled maintenance, provide extended battery life and deliver more consistent power and performance.



Our sophisticated CAN-Bus Network continuously monitors operating systems providing smooth operation and continuous diagnostics of all truck components.

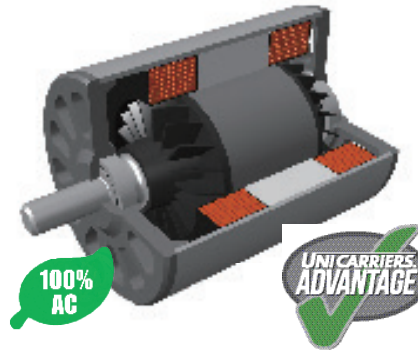

Reliable AC Technology

The SCX Series is powered by our 100% AC motor and hydraulics systems. With **better cooling capacity and greater reliability** even in humid environments, AC power delivers more consistent and higher performance throughout the shift on a single battery charge for more uptime and greater productivity.

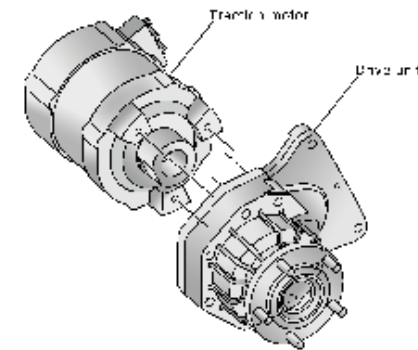

Dependable Drive Units

Dependable performance is achieved through the syncing of our brushless AC induction motors with a simple, yet effective, transmission design. The result is less complexity, fewer parts and reduced maintenance.



Stay Cool

Built-in thermal sensors help protect the motor and controller systems, promoting **more reliable performance**. A warning will flash on the LCD screen to advise the operator if overheating has occurred, followed by reduced travel and lift operations. Information is automatically locked into the truck's service history to assist the technician and speed servicing.



Simple Efficiency

The use of Hall Effect sensors and encoders in the control handle — plus magnetic reed switches and inductive proximity switches — means **no extra wiring of heaters is needed...**and reduces the effect of dirt and debris on the truck's operation.



Reduced Downtime through On-Board Diagnostics

On-board diagnostics and forklift service history are available through the LCD meter panel for **faster troubleshooting and less downtime**. Unlike competitive models, no tablet, laptop or handset tool is needed.





Comfort Zone

Take a look at the features we offer, the materials we use and the thought that went into the SCX Series, and you'll see that we've addressed every aspect of operator comfort in designing this highly efficient truck.

Plush Surroundings



The operator compartment features a padded armrest, an extra tall 57" backrest, super thick floor mat and optional kneepad.

A Smooth Ride



Unlike most competitive forklifts, the platform of the SCX is not bolted to the frame, but sits on **vibration isolators** to absorb shocks.

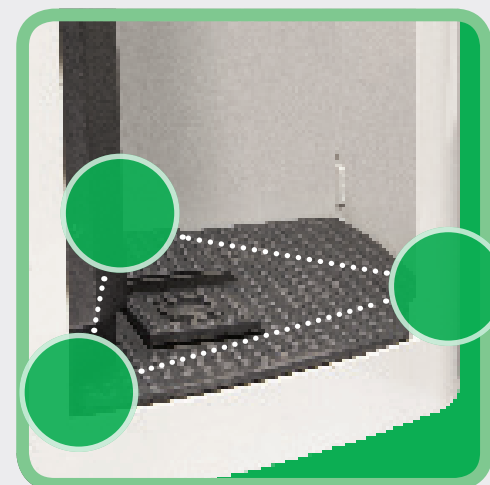

Vibration Isolators

Cushioned Floor Mat

Padded Armrest

57" Backrest

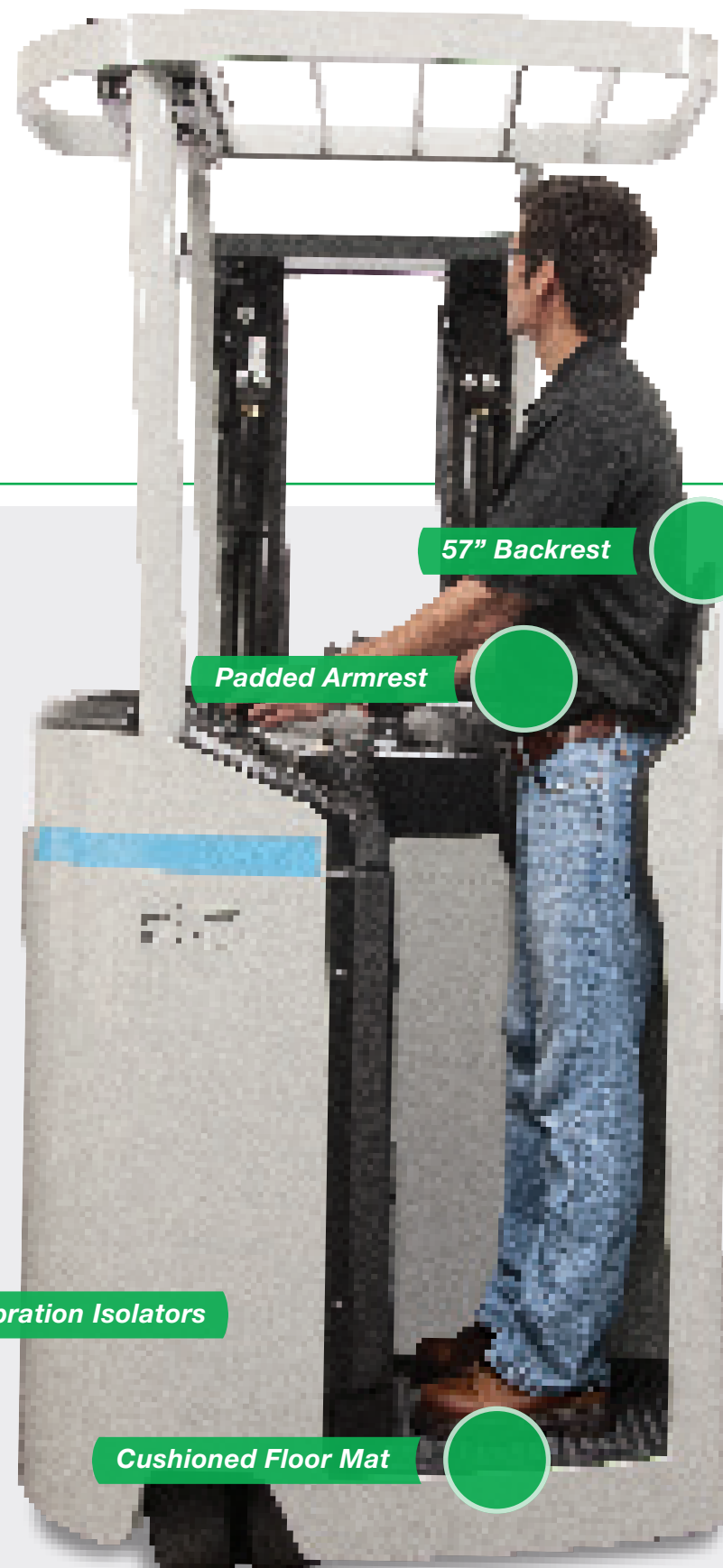

Perfect Vision

The overhead guard is designed with wide canopy channels and an angled crossbar to produce clearer visibility at higher lift heights.



Driver-Friendly Environment

Designed for the operator to lean back comfortably, the floor is angled for optimum foot position, and two large cut-outs accommodate bigger boot sizes. The truck is designed for side stance operation and maximum driver comfort while traveling in either forward or reverse.



Ergo Design

Shaped with an angled grip for comfortable all-day operation, our joystick is ergonomically designed for comfort and ease-of-use — even with freezer gloves. The low-effort, sealed switches help reduce operator fatigue.



Easy Entry

The SCX has the **shortest step height in the industry** at just 8.4" — and along with a wide compartment entry, it is the ideal design for operators who are constantly getting on and off the truck throughout their shifts.

Power & Performance



Smooth Moves

SCX forklifts feature a compact wheelbase and two individually controlled AC motors so it can turn within its own footprint for unsurpassed maneuverability.

3+1 Performance Modes = Greater Productivity

The SCX Series features adjustable settings to optimize performance based on the application, work environment or operator experience. Choose from the three factory-set modes (shown below) to easily customize your lift truck. The SCX also has a manual mode to create unique settings, finely tuned for your operator and operation.

- E Economy Mode**
Extended operating hours achieved with only slightly reduced performance.
- P Power Mode**
Offers mid-range settings for normal performance needs.
- H High-Power Mode**
To reach maximum desired performance.
- M Manual Mode**
Provides access to customize performance parameters.



With quick acceleration, fast travel and lift speeds, plus excellent maneuverability and precise control, the SCX Series delivers optimal performance and productivity in a wide range of applications and environments.

Highly Tuned Performance

Specifically designed for the SCX, the AC motors are matched with a controller that's tuned to their precise torque and power curves. The result is quick acceleration, higher productivity, low energy consumption and industry-leading travel and lift speeds.



Travel Speeds 7.8/8.0 <small>MPH</small> <small>Full load / No load</small>	Lift Speeds 71/114 <small>FPM</small> <small>Full load / No load</small>	Gradeability 29.1 <small>%</small> <small>Loaded</small>
--	---	---

SCX forklifts deliver exceptional power and performance producing faster cycle times and more productive operations.

*Specifications based on 3000 lb capacity model

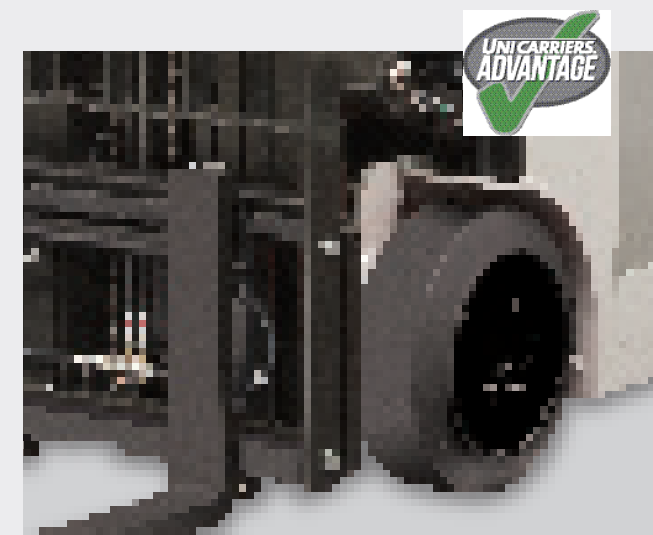

Driving Productivity

Large 18" drive tires provide long wear, exceptional traction and a smooth ride over dock plates, uneven floors and floor joints.



Easy Handling

On-demand power steering with low-input torque, a small steer tiller wheel and tiller knob provide exceptional operator control with minimum effort.

Sweet Savings

From reducing energy consumption to minimizing maintenance costs and maximizing productivity, the SCX is designed and built to lower your operating costs and improve your bottom line profitability.



1,200
2,400

Low Maintenance

Extended major service intervals of 1,200 and 2,400 hours mean more uptime with less time, effort and money expended on maintenance.

IP65 Rated Sealed Controllers

The controllers are fully sealed to **lock out dirt and debris that can harm performance or contaminate internal components**. Highly reliable non-contact switches and sensors also reduce maintenance requirements.

Fewer Motors to Maintain

The 100% AC-powered system on the SCX features brushless drive and pump motors and a single contactor. The steering system is electronically controlled and powered through the hydraulics, thus eliminating the need for — and added expense of — a separate steering motor.

Get the Brake You Need

Our low maintenance brake only needs inspection every 12 months or 2,400 hours.

Save Precious Battery Power

Industrial batteries can be a significant part of your operational expenses. The SCX incorporates power saving features to optimize battery usage so you can get the most out of your investment.

Advanced regenerative technology **reclaims power** from four different operations, lowering power consumption and **reducing component wear** through less heat generation — to keep your equipment **operating longer**, with less time in the charging bay.

An **adjustable auto power-off** cuts the electrical system if the forklift sits idle. Select an allowable idle time between 15 and 60 minutes before the vehicle powers down.

The **on-demand power steering** system draws battery power only when required.

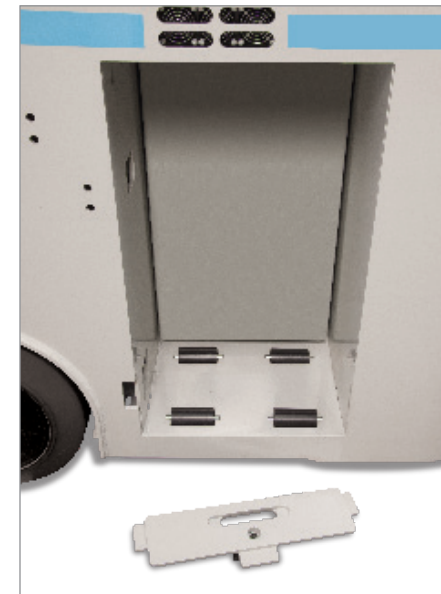
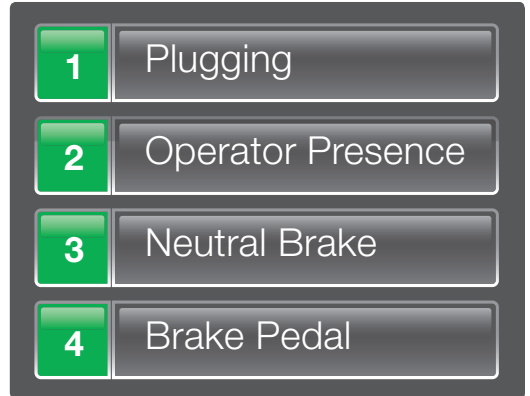

Battery Rollers

Features include standard battery rollers — and an optional battery gate warning option.

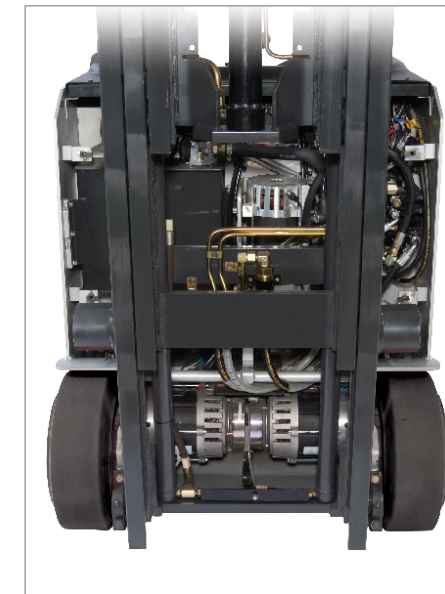

Quick Access

Service points are easily accessible through removable top and front panels for speed and ease of maintenance.

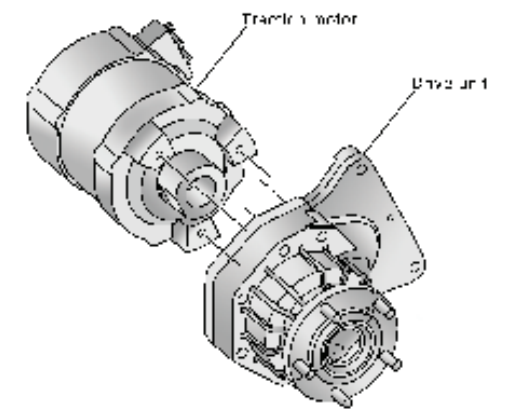

Quick Fix

The modular design of the powertrain speeds and simplifies maintenance. The **gearbox and motor can be removed, serviced and replaced as a single unit** — without removing the mast.

Play It Safe



The SCX Series incorporates the latest technology to improve confidence and security in every aspect of our trucks within your operation.



Security and Customized Performance

Up to five different, customized performance profile settings can be quickly and easily entered through the meter panel. PIN codes help ensure access is only available to authorized operators. Settings may be matched to the skill level of each driver.



Operator Presence Pedal

Divider Bar

Brake Pedal

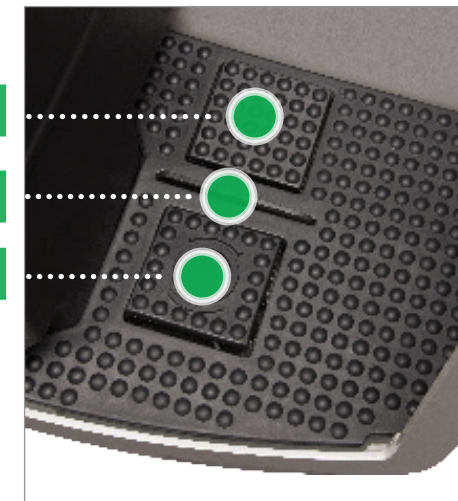

Auto Park

There's no need to set a separate brake because the **parking brake is automatically applied** when travel speed is at 0 and no directional command has been given — or when power to the truck is removed. A divider bar between the pedals ensures both feet must be in the compartment and the operator is in a safe operating position.



Soft Mode

To promote more confident load handling at higher lift heights, the SCX features a "Soft Mode" performance setting for **greater control and easier operation**. Automatically activated when the mast is raised beyond the first stage (or at approximately 47" for a two-stage mast), this design reduces travel, lift, tilt and sideshift speeds; restricts tilt angle; engages tilt interlock and vertical tilt stop; and reduces regeneration braking.



Controlled Rollback with Ramp Hold

If the travel control is returned to neutral while traveling on a ramp, the controller will reduce and stop movement down the slope. When coming to a stop on a ramp, the **SCX controller will apply motor torque to maintain position on the slope**, until the automatic parking brakes apply.



Operator Presence

A standard Operator Presence System requires that both the brake and operator presence pedals are depressed to operate. The SCX offers plenty of room to fit even large work boots comfortably.

Control Freak



Whether it's restricting access to the trucks, regulating the speed at which they travel or limiting operating costs, SCX Series forklifts provide you with the control you need to manage your operation easily, effectively and completely.



Putting Power in Your Hands

Ergonomically designed and intuitive to operate, the multi-function control handle offers simultaneous control of drive, lift-and-lower, horn and auxiliary hydraulic functions.

The Ultimate In Control



Through the meter panel, you can:

- Control access through individual PIN codes
- Customize performance settings to individual operators
- Set speed/acceleration parameters
- Select the optimal performance mode

And gain access to a wealth of vital information to manage your operation including: error codes; operating hours; service history; truck status; and diagnostics.

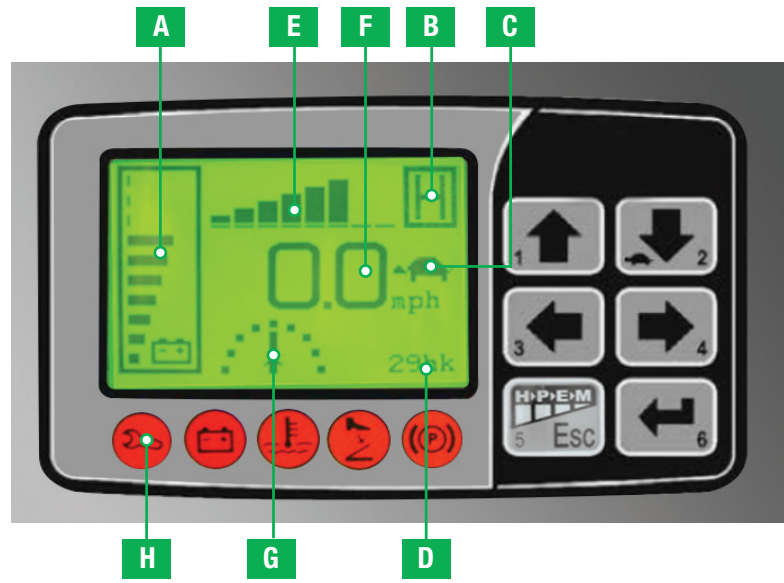

- A** Battery Capacity
- B** Performance Mode
- C** Soft Mode
- D** Hour Meter
- E** Acceleration
- F** Speedometer
- G** Wheel Position
- H** Warning Indicators

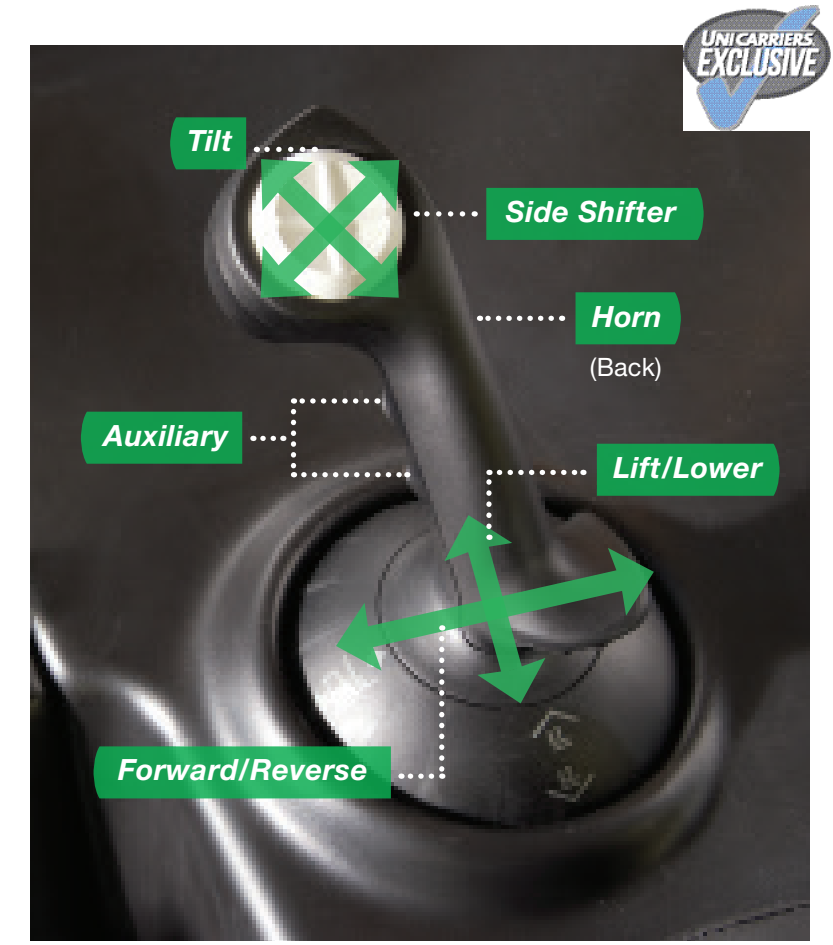

Turn Control

For exceptional maneuverability, the inner wheel counter rotates, and travel speed and acceleration are restricted while turning.

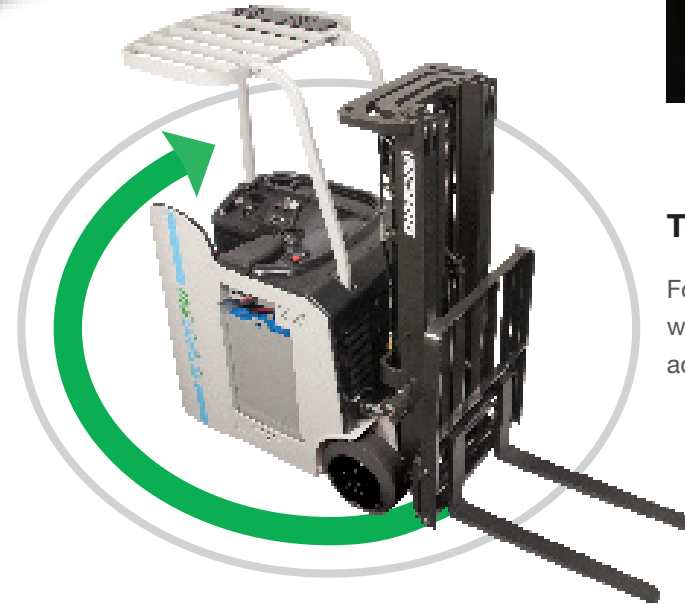

Make It Yours

Unlike competitive brands, UniCarriers trucks come standard with the most essential and popular features and accessories. In addition, we offer a complete menu of additional options that allow you to customize your forklift to fit your specific workplace environment, operations and business objectives. On these pages, you'll find available options that are both innovative and economical — but it's only a portion of what we offer. So if you don't see what you're looking for here, call your authorized dealer for more options.

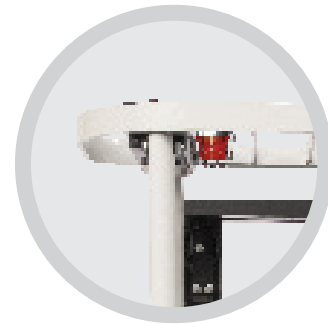

• Rear Strobe Light



• Front Work Lights



Fan & Lighting Package

Fan and compartment light are mounted on the overhead guard canopy for operator comfort and convenience.



Fire Extinguisher

2.5 lb. ABC type — mounts within easy reach of the operator.



Cushioned Knee Pad

Provides greater operator comfort, especially during long work shifts.



Battery Gate Interlock Switch

Prevents truck travel if the battery gates are not installed correctly. Operator is notified through an error code on the meter panel.



Side Shifter

Operators will experience greater efficiency due to fewer required moves when storing and retrieving loads. Integral or hang-on designs available.



Tilt Cylinder Boots

Added protection against condensation, dirt and dust.

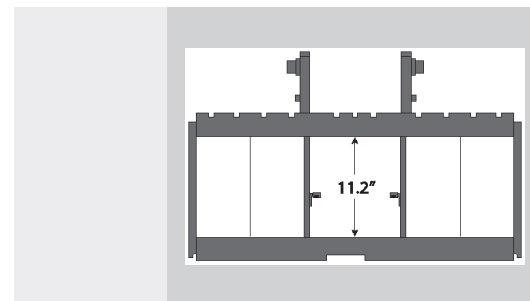

High Visibility Carriage

Offers 38% increased vertical open space between the carriage bars for enhanced visibility.



Lower Overhead Guard

Low 83.3" profile for more confined, height-restricted areas. Other heights available.



Freezer Package

For operating in environments as low as -22°F (-30°C) — includes special hydraulic oil and tilt cylinder boots.

Option Availability

● Standard ○ Optional

VEHICLE MANAGEMENT	
AC TECH motor controller system	●
AC dual drive motors and AC hydraulic pump motor	●
Interactive LCD meter panel with adjustable performance settings	●
Operator security PIN access	●
Controlled rollback	●
3 preset performance modes (Economy, Power, High Power)	●
1 manual (custom) performance mode	●
On-board diagnostics, self-test and coded service history	●
Low battery lift interrupt system	●
BATTERY / ELECTRICAL	
Battery compartment rollers and side gates	●
Battery gate interlock switch	○
Emergency power disconnect switch	●
Adjustable auto power off	●
Anti-static ground strap	●
BRAKE	
Electro-magnetic parking brake (automatically applied)	●
4-mode regenerative braking	●
MAST	
Auto-mast lock system	●
High visibility carriage	●
HYDRAULIC SYSTEM	
On-demand priority hydraulic power steering with tiller control	●
OPERATOR CONVENIENCES	
Side stance operator compartment	●
Ergonomically sloped floorboard with vibration isolators	●
Multi-function control handle	●
Forward steering (forks leading)	●
Reverse steering (forks trailing)	○
Cushioned floor mat, back and armrest padding	●
Cushioned knee padding	○
Integrated clipboard and amenity tray	●
Low overhead guard	○
Overhead guard mounted LED headlights	○
Rear overhead guard mounted LED work light	○
Operator fan and light package (mounted to overhead guard console)	○
Freezer package	○
Strobe light	○
PROTECTION / SECURITY	
Operator presence system with return-to-neutral & auto mast lock	●
Reduced speeds and tilt above free lift	●
Travel alarm (forward, reverse or both)	○
Fire extinguisher	○

Specifications

SHORT MODEL CODES	SCX30SN	SCX30N	SCX35N	SCX40N
Capacity - lb	3,000	3,000	3,500	4,000
Voltage	36	36	36	36
Frame	Short	Standard	Standard	Long
Length - in (mm)	66 (1680)	68.2 (1735)	68.2 (1735)	70.5 (1790)
Wheelbase - in (mm)	41.8 (1065)	43.9 (1115)	43.9 (1115)	46.3 (1175)
Turning Radius - in (mm)	52.3 (1330)	54.5 (1385)	54.5 (1385)	56.8 (1445)
Min. Right Angle Stack - in (mm)	66.9 (1700)	69.1 (1755)	69.1 (1755)	71.4 (1815)
Battery Compartment - in	38.5 x 16.3 x 32	38.5 x 18.4 x 32	38.5 x 18.4 x 32	38.5 x 20.8 x 32
Max. Ah Capacity - (6 hr rate)	930	1085	1085	1240
Min/Max Battery Weight - lb	1885 / 2400	2175 / 2700	2175 / 2700	2460 / 3000



Power, performance and reliability...all backed by the best standard limited warranty in the business!*

- 2 Years
- Unlimited Hours

* Contact UniCarriers Americas for specific details, limitations, and exclusions.